

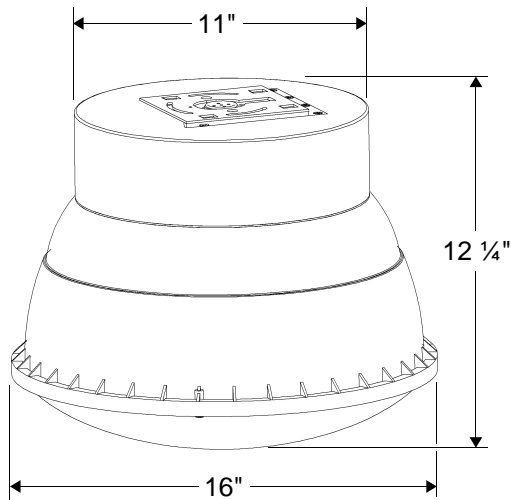

## SQGL304T<sup>SERIES</sup> Direct / Indirect Surface Mount Area Light 26W, 32W or 42W Compact Fluorescent Lamps



**Application:** Ideal for parking garages, entrances, walkways, loading docks, recreation areas and other general applications.

### Specifications

**Housing:** Heavy duty die cast aluminum with quick mount system. See finish note.

**Mounting Bracket:** EZ5 bracket fits standard 4" electrical box and allows one person installation with two hands free for wiring.

**Lens:** Polycarbonate lens / refractor computer designed for wide distribution pattern, gasketed to frame. Lens hinged to allow for easy re-lamping.

**Reflector:** Two piece anodized aluminum reflector, with removable upper section to provide up-light component. Designed in conjunction with the lens for efficiency.

**Ballast:** Compact fluorescent electronic high power factor class P, universal voltage 120 thru 277 volt; 50/60 Hz.

**Lamp: (3) or (4)** Compact fluorescent PLT lamps max. 42W, 4 pin base (by others). See ordering information.

#### Lamp Holder

White thermoplastic with snap-in lamp retainer springs. See ordering information.

**Finish:** White, bronze or gray detergent cleaned, prime coated. Chip resistant powder urethane polyester coating, electrostatic applied and baked.

**Photometric Information:** Contact factory.

**Labels:** U/L, CU/L listed suitable for wet location, under covered ceiling applications. I.B.E.W. labeled.

*SPECIFICATIONS SUBJECT TO CHANGE WITHOUT NOTICE*

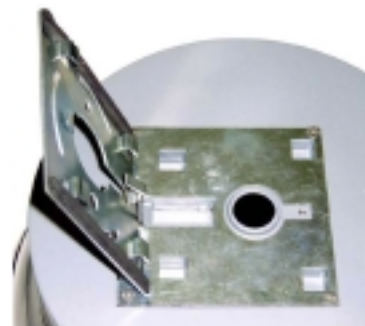

EZ5 Mounting Bracket

### Ordering Information

Catalog Number	Watts	Lamp Base
SQGL303T3	3-PLT26W	GX24q-3
SQGL303T4	3-PLT32W	GX24q-3
SQGL303T5	3-PLT42W	GX24q-4
SQGL304T3	4-PLT26W	GX24q-3
SQGL304T4	4-PLT32W	GX24q-3
SQGL304T5	4-PLT42W	GX24q-4