

SPECIFICATIONS

Housing: Heavy duty die cast aluminum construction with corrosion resistant hardware. See finish note.

Door Frame: Heavy duty die cast aluminum, one piece silicone gasket, seals door frame to housing. See finish note.

Lens: Impact resistant clear tempered glass, silicone caulked to door frame.

Reflector: Anodized aluminum, designed for maximum efficiency.

Ballast: Pre-wired C.W.A., H.P.F. core and coil with capacitor.

Lamp: Clear medium base, (by others).

Lamp Holder: High heat 4 K.V. rated, w/nickel plated copper screw shell, spring loaded center contact, lamp grips, SF-2 leads (200° C). Impregnated gasket.

Finish: Dark Bronze, detergent cleaned, prime coated. Chip resistant powder urethane polyester coating, electrostatic applied and baked.

Photometric Information: Contact factory.

Labels: U/L, CU/L listed suitable for wet location.

I.B.E.W. labeled.



APPLICATIONS

Ideal for parking areas, entrances, walkways, underpasses, loading docks and tunnels.

DIMENSIONS

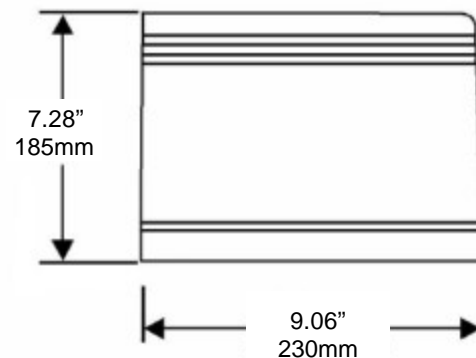
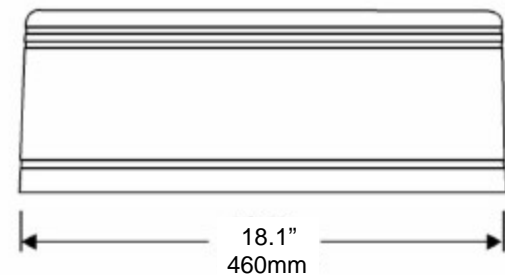

SPECIFICATIONS SUBJECT TO CHANGE WITHOUT NOTICE

Ordering Information

Catalog Number	Watts	Light Source
GSMU30212	50	HPS
GSMU30213	70	HPS
GSMU30214*	100	HPS
GSMU30215*	150	HPS
GSMU30222	50	MH
GSMU30223	70	MH
GSMU30224	100	MH
GSMU30225	150	MH
GSMU30226	175	MH

*120V only.



3254 North Kilbourn Avenue Chicago, Illinois 60641-4505
 Phone: 773-427-7000 Fax: 800-217-1260 www.escolighting.com

A Woman-Owned Business
 Established 1975

