

SPECIFICATIONS

Housing: Heavy duty die cast aluminum construction with corrosion resistant hardware. See finish note.

Door Frame: Heavy duty die cast aluminum, one piece silicone gasket, seals door frame to housing. See finish note.

Lens: Impact resistant clear tempered glass, silicone caulked to door frame.

Reflector: Anodized aluminum, designed for maximum efficiency.

Ballast: Pre-wired C.W.A., H.P.F. core and coil with capacitor.

Lamp: Clear mogul base, medium base for 50W metal halide (by others).

Lamp Holder: High heat 4 K.V. rated, w/nickel plated copper screw shell, spring loaded center contact, lamp grips, SF-2 leads (200° C). Impregnated gasket.

Finish: Dark Bronze, detergent cleaned, prime coated. Chip resistant powder urethane polyester coating, electrostatic applied and baked.

Photometric Information: Contact factory.

Labels: U/L, CU/L listed suitable for wet location.



APPLICATIONS

Ideal for parking areas, entrances, walkways, underpasses, loading docks and tunnels

HOW TO ORDER

Catalog Number	Watts	Light Source
GSM11612**	50	HPS
GSM11613**	70	HPS
GSM11614*	100	HPS
GSM11615*	150	HPS
GSM11622***	50	MH
GSM11623	70	MH
GSM11624	100	MH
GSM11625	150	MH
GSM11626	175	MH

*120V only. ** 120V-277V only.
***Medium base lamp.

DIMENSIONS

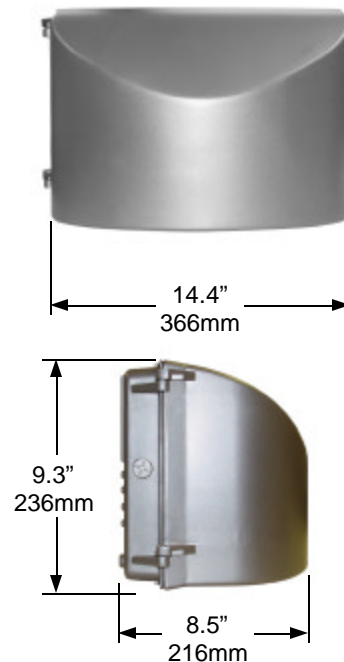

3254 North Kilbourn Avenue Chicago, Illinois 60641-4505
Phone: 773-427-7000 Fax: 800-217-1260 www.escolighting.com

A Woman-Owned Business
Established 1975

